

Multi-angle Log Splitter Spare Parts List--15T & 22T

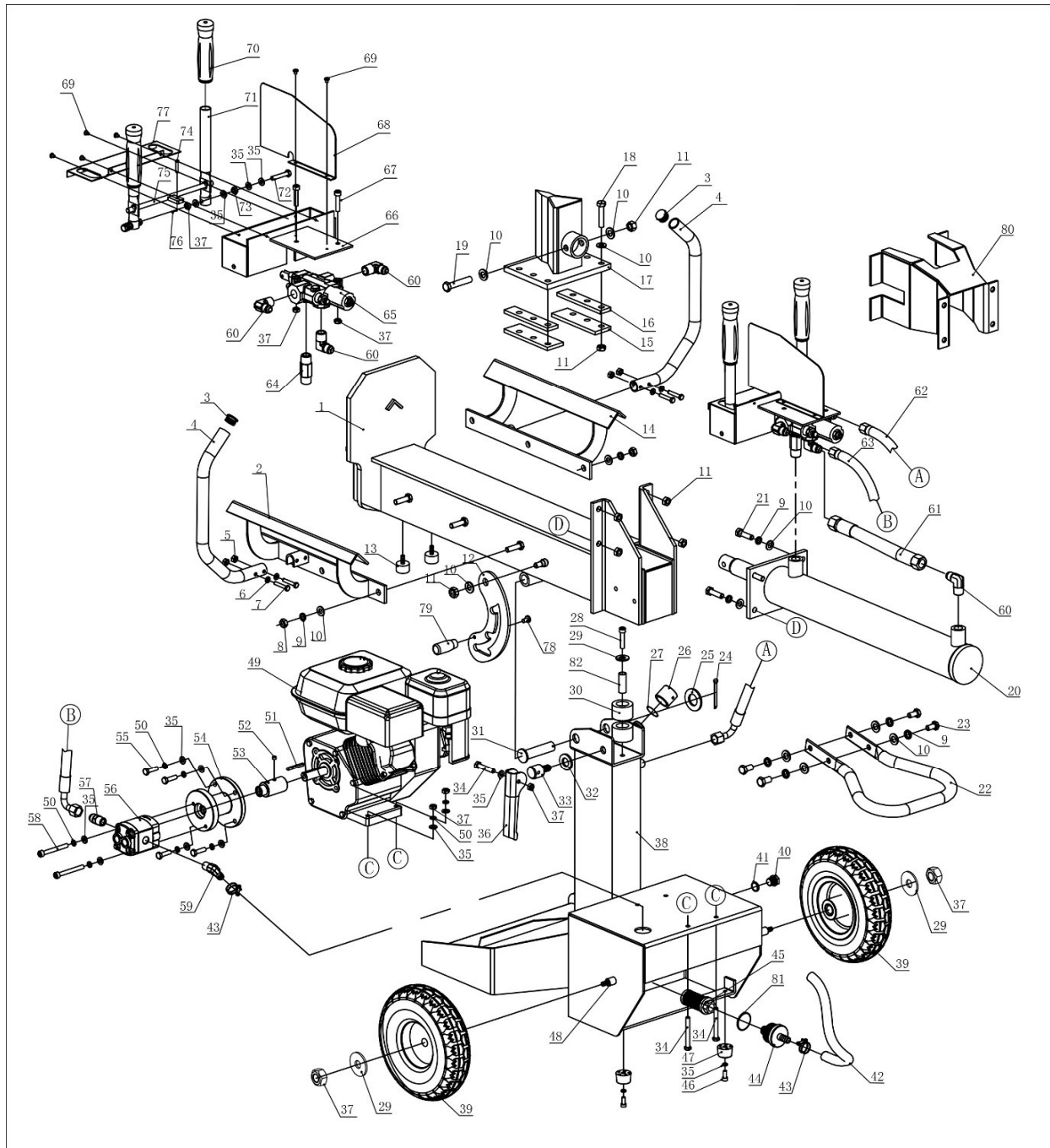

No.	Description by CN	Description by EN	Qty/unit	Order QTY	No.	Description by CN	Description	Qty/unit	Order QTY
1	底座组件	Beam	1		42	低压软管(吸油管)	Suction pipe	1	
2	圆木导向板组件(左)	Left log guider	1		43	钢丝抱箍	Hoop	2	
3	管帽	Tube cap	2		44	进油管螺母	Inlet pipe connector	1	
4	挡管	Log guard	2		45	网式吸油过滤器	Oil filter	1	
5	M6非金属嵌件自锁螺母	Lock nut M6	4		46	M8x20内六角圆柱螺钉	Bolt M8x20	4	
6	φ6xφ12x1.5平垫圈	Flat washer φ6xφ12x1.5	4		47	机脚	Rubber foot	4	
7	M6x40外六角螺栓	Bolt M6x40	4		48	轮杆	Wheel shaft	1	
8	M10六角螺母(加厚)	Nut M10	6		49	汽油机	Engine	1	
9	φ10弹簧垫圈	Spring washer φ10	14		50	φ8弹簧垫圈	φ8 Spring washer	10	
10	φ10xφ20x2平垫圈	Flat washer φ10xφ20x2	22		51	平键	Flat key	1	
11	M10非金属嵌件自锁螺母	Lock nut M10	12		52	内六角锥端紧定螺钉M8x6	Bolt M8x6	1	

12	固定板	Lock metal plate	1	53	汽油机联轴器	Shaft connector	1
13	橡胶垫脚	Rubber absorber	2	54	联轴器座	Shaft connector holder	1
14	圆木导向板组件(右)	Right log guider	1	55	M8x30外六角螺栓	Bolt M8x30	4
15	轨道平板	Wedge plate	2	56	齿轮泵	Gear pump	1
16	衬板	Wedge spacer	2	57	接头 3/8-M18x1.5	Connector 3/8-M18x1.5	1
17	刀座组件	Wedge	1	58	M8x90内六角圆柱头螺钉	Bolt M8x90	2
18	M10x45外六角螺栓	Bolt M10x45	6	59	齿轮泵进油管接头	Pupm connector	2
19	M10x65外六角螺栓	Bolt M10x65	1	60	1/2-M18x1.5 角通	Connector 1/2 -M18 x1.5	4
20	油缸总成	Cylinder	1	61	高压油管B	Oil pipe B	1
21	M10x40外六角螺栓	Bolt M10x40	4	62	高压油管A(回油短管)	Oil pipe A	1
22	扶手	Support handle	1	63	高压油管C(进油长管)	Oil pipe C	1
23	M10x16外六角螺栓	Bolt M10x16	4	64	管接头	Connector	1
24	开口销4*36	Cotter pin φ4x36	1	65	控制阀	Control valve	1
25	φ20*φ37*φ3平垫圈	Flat washer Φ20xφ37xφ3	1	66	连接架组件	Valve holder	1
26	油盖	Oil tank cap	1	67	内六角圆柱头螺钉 M8x40	Bolt M8x40	2
27	O型圈25*3.55	O-ring 25x3.55	1	68	垂直护板	Vertical plate	1
28	M8x50内六角圆柱螺钉	Screw M8x50	1	69	十字槽盘头螺钉 M5x6	Screw M5x6	6
29	φ8*φ24*φ2平垫圈	Flat washer Φ8xφ24x2	3	70	手柄套	Handle cover	2
30	橡胶减震块	Rubber mat	2	71	控制阀操纵手柄	Control handle	2
31	销轴	Pin	1	72	外六螺栓 M8x45	Bolt M8x45	2
32	φ14xφ60x3平垫圈	Flat washer Φ14xφ60x3	1	73	六角螺母 M8	Nut M8	2
33	锁紧轴	Lock shaft	1	74	销轴 5x25B	Pin 5x25B	1
34	M8x40外六角螺栓	Bolt M8x40	5	75	连接杆	Connect rod	1
35	φ8平垫圈	Flat washer φ8	23	76	开口销 φ1.6x10	Cotter Pin φ1.6x10	1
36	锁紧手柄	Lock handle	1	77	连接架盖	Valve Cover	1
37	M8非金属嵌件自锁螺母	Lock nut M8	11	78	M6*10半圆头螺钉	Screw M6x10	1
38	机架组件	Body frame	1	79	小手柄	Handle bar	1
39	10"轮子(充气轮)	10" Pneumatic tire	2	80	护刀	Wedge protector	1
40	放油螺塞 M16x1.5	Drain plug M16x1.5	1	81	34.5x2.65 O型圈	O-ring 34.5x2.65	1
41	组合垫圈 φ16	Combination washer φ16	1	82	隔套管	Space tube	1
				20-1	油缸上连接头和密封圈		